

**FAG**



## Split Spherical Roller Bearings

**Distribuidor Autorizado:**



**Rolamentos CBF Ltda.**  
Tel +55 11 3824-6400  
E-mail: [vendas@cbfcorp.com.br](mailto:vendas@cbfcorp.com.br)  
[www.rolamentoscbf.com.br](http://www.rolamentoscbf.com.br)

**SCHAEFFLER**





# Contents

	Page
<b>Features</b>	
Cost savings .....	2
Replacement for bearings with adapter sleeve .....	3
Mounting in split plummer block housings .....	4
Application examples .....	6
Product range .....	9
Bearing design.....	9
<b>Design and safety guidelines</b>	
Load carrying capacity .....	11
Speed suitability.....	11
Fits .....	11
Lubrication .....	12
FAG SmartCheck .....	13
Mounting of split spherical roller bearings.....	13
<b>Dimension tables</b>	
FAG spherical roller bearings, split, metric sizes .....	16
FAG spherical roller bearings, split, inch sizes .....	22

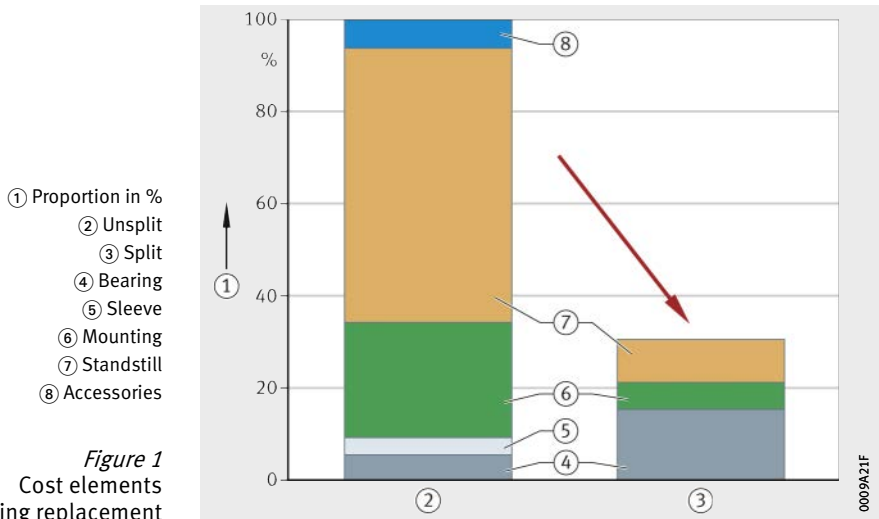
# Split FAG spherical roller bearings

**Features** Spherical roller bearings are double row units comprising solid outer rings with a concave raceway, solid inner rings and barrel rollers with cages. The symmetrical barrel rollers orient themselves freely on the concave outer ring raceway. As a result, shaft flexing and misalignment of the bearing seats are compensated.

In split spherical roller bearings, the inner ring, outer ring and cage with the roller set are split in half. The split bearing rings are held together by screws.

**Cost savings** Split spherical roller bearings are principally used where the replacement of unsplit spherical roller bearings would require costly additional work, involving the removal of gears or couplings, the dismantling of drives or the dismantling of shaft power trains. The use of split spherical roller bearings reduces the downtime of machinery and plant.

In new designs too, split spherical roller bearings can give cost savings in many cases since the plant can be simplified and the assembly work required is reduced. Due in particular to the reduced downtime, the mounting of split spherical roller bearings gives a significant reduction in mounting costs, *Figure 1*.

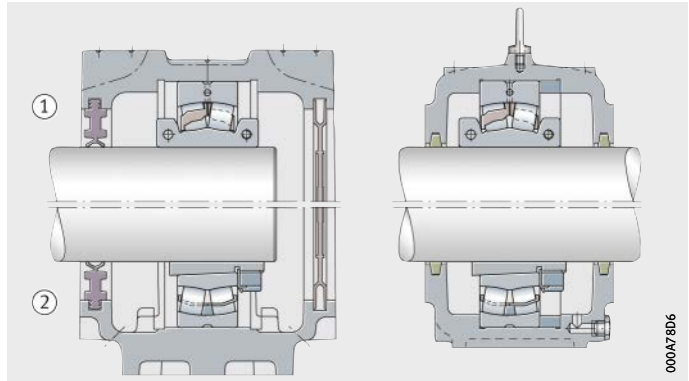


## Replacement for bearings with adapter sleeve

Split spherical roller bearings can generally be mounted instead of unsplit spherical roller bearings with adapter sleeves. The preconditions for replacement are that the outside diameter, outer ring width and diameter of the shaft seat are identical and that the bearings are suitable for the load case, *Figure 2*.

- ① Split spherical roller bearing
- ② Unsplit spherical roller bearing with adapter sleeve

*Figure 2*  
Simple bearing replacement



# Split FAG spherical roller bearings

## Mounting in split plummer block housings

Split spherical roller bearings can in many cases be mounted in our split plummer block housings. At difficult to access locations in particular, this combination of a split bearing and split housing gives considerably easier mounting of bearings, *Figure 3*, page 5.

The housings are specifically designed for the location of spherical roller bearings. Split FAG plummer block housings and the associated bearings form bearing arrangement units that can be matched, through the specific selection of seal design, lubrication type and bearing mounting, to a wide range of requirements.

The suitable housing for your split FAG spherical roller bearing can be found in the dimension tables starting from page 16.

In order to ensure selection of the correct combination of housing and bearing when using split bearings, please contact Schaeffler.



*Figure 3*  
Split spherical roller bearing  
in a split SNS housing  
with split labyrinth seal

**Further information**

- TPI 231, Split Plummer Block Housings SNS
- TPI 175, Split Plummer Block Housings SNV.

# Split FAG spherical roller bearings

## Application examples

A common application for split spherical roller bearings is on shafts supported at several points and difficult to access mounting locations. Typical areas of application include conveying equipment, materials processing plant, ventilation plant, rolling mills, ships and paper machinery.

Application examples in mining and materials processing, *Figure 4* and *Figure 5*, page 7:

- Bucket wheel excavators and reclaimers
- Winches and sheaves, drive and transmission shafts
- Worm conveyors, bucket conveyors and conveyor belts
- Mixing and stirring plant, mills and crushers
- Sintering plant, rotary kilns
- Fans and ventilators, dust extraction plant.



*Figure 4*  
Bearing arrangements  
in comminution and  
processing plant



*Figure 5*  
Drive bearing arrangements  
in conveying and  
transport equipment



# Split FAG spherical roller bearings

Application examples in the pulp and paper industry, *Figure 6* and *Figure 7*:

- Fans and ventilators
- Mixing and stirring plant
- Dryer rolls
- Drive and transmission shafts
- Conveying equipment
- Comminution machinery.

*Figure 6*  
Bearing arrangements  
in fans and ventilators



*Figure 7*  
Mounting of a large split spherical  
roller bearing



## Product range

The comprehensive range contains split spherical roller bearings for metric shaft diameters from 55 mm to 630 mm and for inch size shafts from  $2\frac{3}{16}$  inch to 16 inch.

In most cases, the outside diameter, outer ring width and diameter of the shaft seat are identical to those of standard spherical roller bearings of series 222, 230, 231, 239, 240 and 241 with appropriate adapter sleeves.

Which standard bearing with a sleeve can be replaced by the split bearing is shown in the dimension tables.

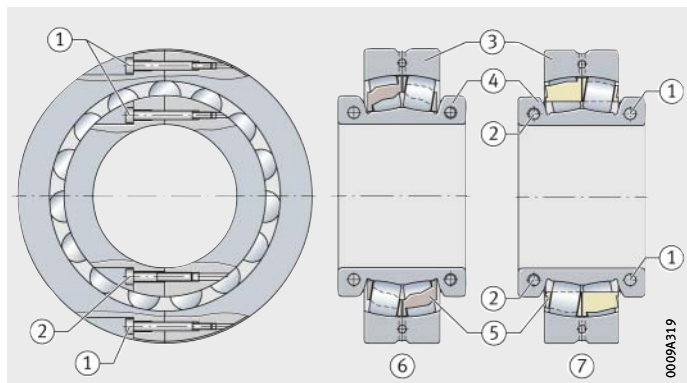
## Bearing design

Split spherical roller bearings have a cylindrical bore.

The internal construction of most split spherical roller bearings was carried over from our proven spherical roller bearing, *Figure 8*.

- ① Shim
- ② Clamping screw
- ③ Outer ring halves
- ④ Inner ring halves
- ⑤ Cage halves with roller and cage assemblies
- ⑥ Polyamide cage
- ⑦ Brass cage

*Figure 8*  
Internal construction of bearings  
with integrated locking rings



## Split FAG spherical roller bearings

The bearings have a split solid cage made from glass fibre reinforced polyamide or brass, see Catalogue HR 1, Rolling Bearings.

Split spherical roller bearings have the normal tolerances of unsplit radial bearings and the normal internal clearance of unsplit spherical roller bearings with a cylindrical bore (ISO 492:2014).

In most split spherical roller bearings, the locking rings are integrated in the inner rings, *Figure 9*.



*Figure 9*

Split spherical roller bearing with split solid cage made from glass fibre reinforced polyamide or brass, with integral locking rings

If there are large differences in temperature between the shaft and inner ring halves, which can occur for example in dryer rolls for paper machinery, bearings with separate locking rings are more suitable, *Figure 10*.



*Figure 10*

Split spherical roller bearing for special applications with separate, split locking rings

## **Design and safety guidelines**

### **Load carrying capacity**

Due to the screw connection in the outer ring, the pitch circle for the rolling element set is smaller than that of an unsplit spherical roller bearing. As a result, the load carrying capacity of split spherical roller bearings is lower by comparison. Since they contain the maximum number of rollers with the largest possible dimensions, they can nevertheless achieve a high load carrying capacity.

The overrolling of the joints is taken into consideration in calculation of the equivalent dynamic load by applying the shock factor 1,1. Dimensioning is carried out according to the normal calculation method from Catalogue HR 1, Rolling Bearings.

### **Speed suitability**

The dimension tables give the limiting speeds.

The values take account of the cage strength and the vibrations generated through overrolling of the joints. If the limiting speeds are exceeded, consultation with Application Engineering is required.

### **Fits**

In order that the inner rings have the necessary tight fit once the screws have been tightened, the shaft must be machined to between h6 and h9. These shaft tolerances are the same as those normally used with unsplit bearings located by means of adapter sleeves. The housing bore is normally machined to H7 or H8.

## Split FAG spherical roller bearings

**Lubrication** Split spherical roller bearings are normally lubricated using grease. The lubrication intervals correspond to those of unsplit bearings. Split spherical roller bearings can also be relubricated via a groove and holes in the outer ring.

The use of split spherical roller bearings in conjunction with the automatic relubrication devices FAG CONCEPT8 or FAG CONCEPT2 is particularly effective. Through controlled relubrication, a sufficient quantity of fresh lubricant is continuously supplied to the contact points of the rolling bearing. This results in a significant increase in bearing life. The devices extend the lubrication and maintenance intervals and prevent undersupply or oversupply of lubricant. Plant downtime and maintenance costs are reduced as a result. The sparing and environmentally friendly use of lubricants contributes to higher cost-efficiency, *Figure 11*.



0001ABF9

*Figure 11*  
Plummer block housing SNS with  
automatic lubricator FAG CONCEPT8

**Further information** ■ TPI 252, Automatic Relubrication Devices.

## FAG SmartCheck

Condition monitoring and diagnosis of split spherical roller bearings can be carried out using FAG SmartCheck. This is a cost-effective, innovative online measuring system for the continuous monitoring of machine and process parameters on a decentralised basis.

FAG SmartCheck allows recording of vibrations and process parameters such as speed and temperature and thus facilitates monitoring of the bearings. The automatic alarm threshold adjustment allows a reliable alarm system. The alarm system can be implemented in a WLAN on a smartphone by means of the free-of-charge SmartCheck APP.

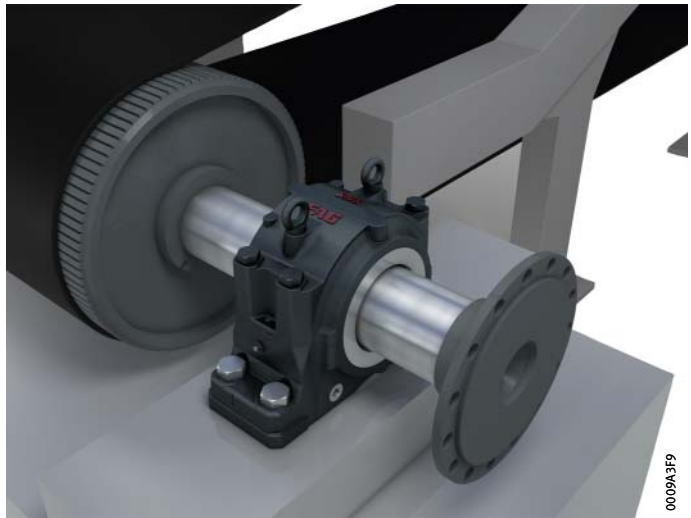
Split FAG plummer block housings SNS are equipped as standard with a connection point to which FAG SmartCheck can be screw mounted. If a suitable connection point with a hole is not present, FAG SmartCheck can be attached by means of adhesive or a magnet.

### Further information

■ TPI 214, FAG SmartCheck.

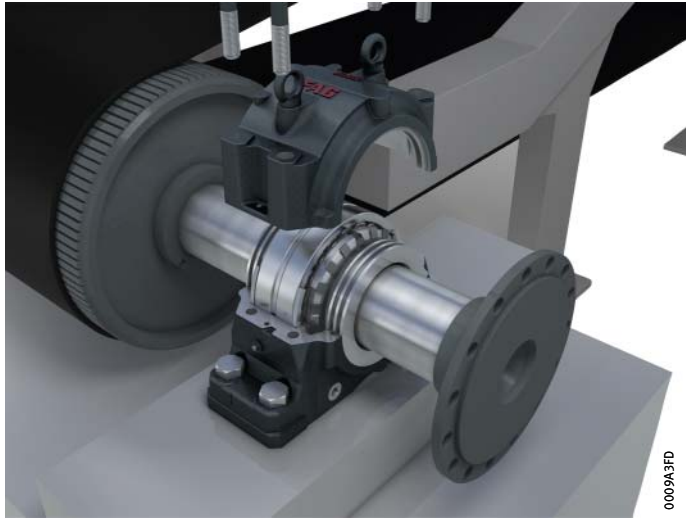
## Mounting of split spherical roller bearings

The following pictures give a summary of the operations in the mounting of split spherical roller bearings. Each bearing is supplied with a comprehensive mounting manual, *Figure 12* to *Figure 18*, page 15.

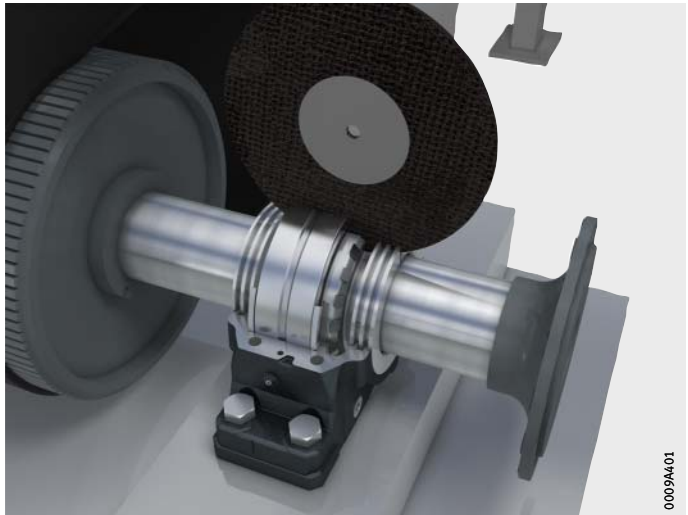


*Figure 12*  
Support the rotor

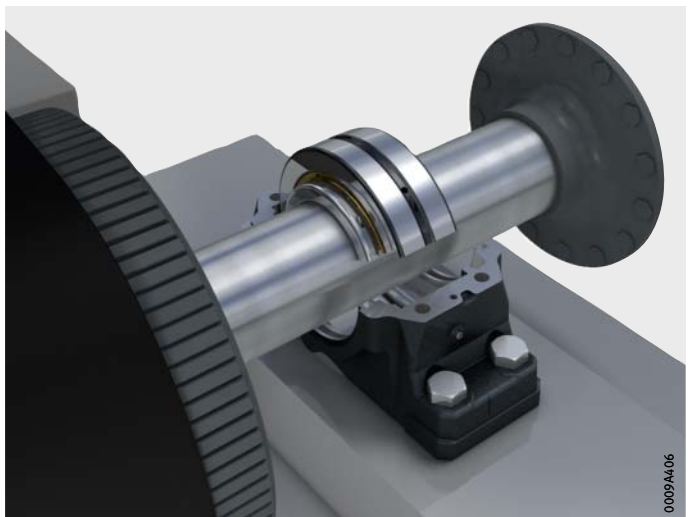
## Split FAG spherical roller bearings



*Figure 13*  
Remove the housing cover



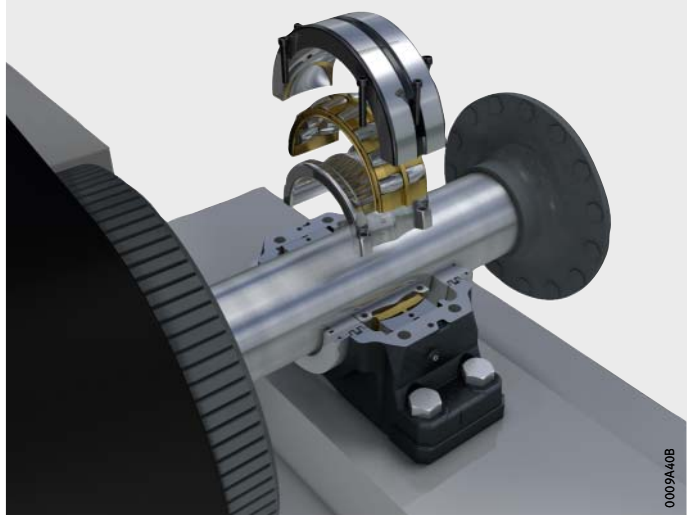
*Figure 14*  
Dismount the old bearing



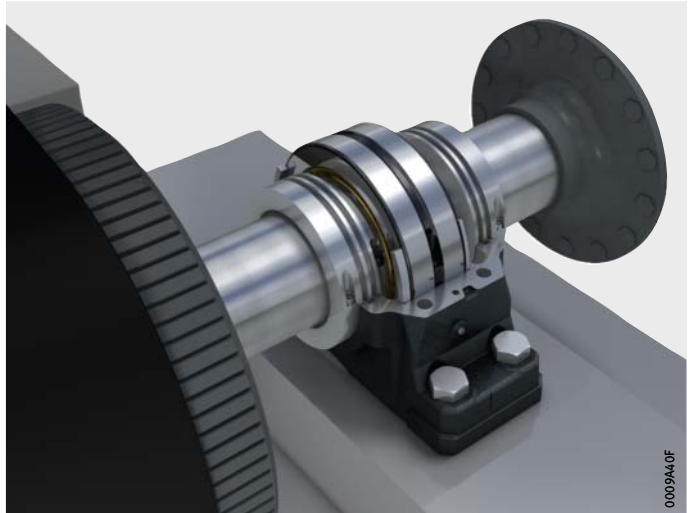
*Figure 15*  
Insert the outer ring half  
in the lower housing section



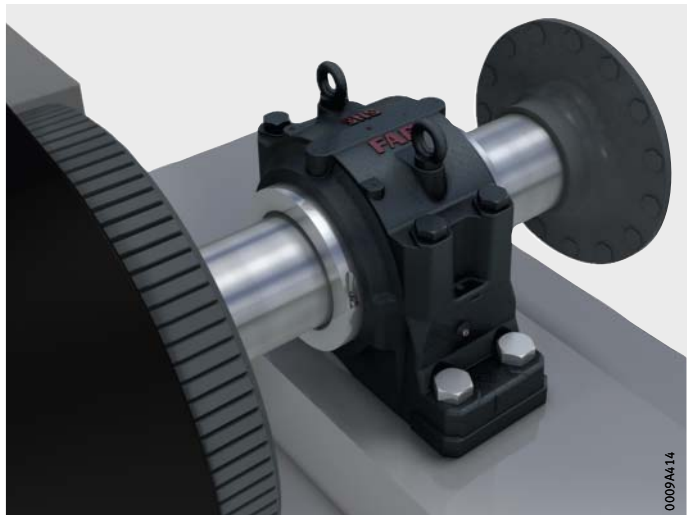
*Figure 16*  
Mount the remaining parts



*Figure 17*  
Lower the shaft

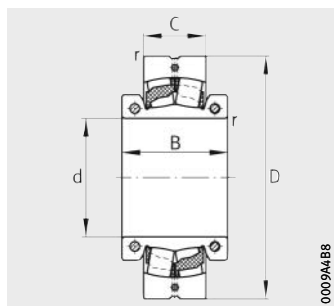


*Figure 18*  
Mount the upper housing section

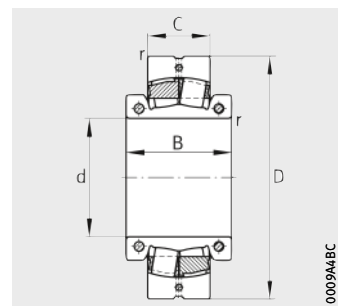


# FAG spherical roller bearings

Split, metric sizes



Solid polyamide cage  
TVPA

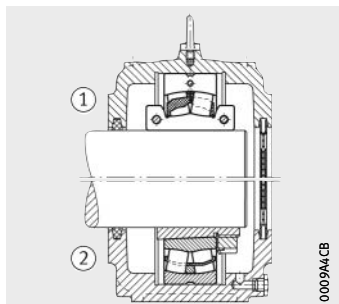


Solid brass cage  
MA

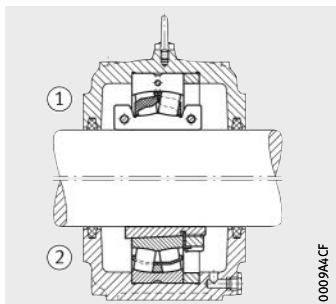
Dimension table · Dimensions in mm

Designation	Mass ≈ kg	Dimensions					Basic load ratings		Calculation factors			
		d	D	C	B	r min.	dyn. C <sub>r</sub> kN	stat. C <sub>0r</sub> kN	e	Y <sub>1</sub>	Y <sub>2</sub>	Y <sub>0</sub>
<b>222SM55-TVPA</b>	1,47	<b>55</b>	110	28	52	1,5	110	130	0,21	3,17	4,72	3,1
<b>222SM60-TVPA</b>	2,08	<b>60</b>	120	31	55	1,5	136	155	0,23	2,98	4,44	2,92
<b>222SM65-TVPA</b>	2,61	<b>65</b>	130	31	60	1,5	172	210	0,24	2,81	4,19	2,75
<b>222SM70-TVPA</b>	3,18	<b>70</b>	140	33	62	2	180	226	0,23	2,95	4,4	2,89
<b>222SM75-TVPA</b>	3,96	<b>75</b>	150	36	68	2	184	237	0,22	3,1	4,62	3,03
<b>222SM80-TVPA</b>	4,82	<b>80</b>	160	40	70	2	213	270	0,22	3,14	4,67	3,07
<b>222SM85-TVPA</b>	5,79	<b>85</b>	170	43	74	2	260	325	0,22	3,04	4,53	2,97
<b>222SM90-TVPA</b>	6,59	<b>90</b>	180	46	76	2,1	285	360	0,23	2,9	4,31	2,83
<b>231SM100-MA</b>	6,8	<b>100</b>	180	56	90	2	310	430	0,28	2,37	3,53	2,32
<b>222SM100-TVPA</b>	10,1	<b>100</b>	200	53	92	2,1	360	460	0,24	2,84	4,23	2,78
<b>230SM110-MA</b>	5,61	<b>110</b>	180	46	86	2	270	385	0,23	2,9	4,31	2,83
<b>231SM110-MA</b>	9,51	<b>110</b>	200	62	102	2	395	570	0,28	2,41	3,59	2,35
<b>222SM110-TVPA</b>	12,1	<b>110</b>	215	58	98	2,1	460	590	0,25	2,71	4,04	2,65
<b>230SM115-MA</b>	10,5	<b>115</b>	200	52	90	2	305	455	0,22	3,04	4,53	2,97
<b>231SM115-MA</b>	11,2	<b>115</b>	210	64	104	2	490	700	0,28	2,39	3,56	2,34
<b>222SM115-TVPA</b>	15,3	<b>115</b>	230	64	104	3	540	720	0,25	2,71	4,04	2,65
<b>230SM125-MA</b>	10	<b>125</b>	210	53	94	2	395	600	0,23	2,95	4,4	2,89
<b>231SM125-MA</b>	13,5	<b>125</b>	225	68	110	2,1	510	750	0,28	2,45	3,64	2,39
<b>222SM125-TVPA</b>	19,3	<b>125</b>	250	68	110	3	630	870	0,26	2,62	3,9	2,56
<b>230SM135-MA</b>	13	<b>135</b>	225	56	100	2,1	405	620	0,22	3,07	4,57	3
<b>231SM135-MA</b>	19,5	<b>135</b>	250	80	123	2,1	570	850	0,27	2,49	3,71	2,43
<b>222SM135-TVPA</b>	24,7	<b>135</b>	270	73	122	3	730	1020	0,25	2,67	3,97	2,61
<b>230SM140-MA</b>	15,5	<b>140</b>	240	60	106	2,1	445	690	0,22	3,1	4,62	3,03
<b>231SM140-MA</b>	25,8	<b>140</b>	270	86	135	2,1	710	1050	0,29	2,32	3,45	2,26
<b>222SM140-TVPA</b>	29,7	<b>140</b>	290	80	124	3	850	1190	0,25	2,69	4	2,63

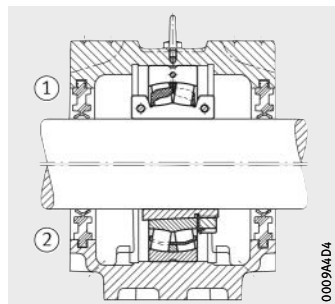
① Split spherical roller bearing. ② Unsplit spherical roller bearing.



Non-locating bearing  
S30



Locating bearing  
S30

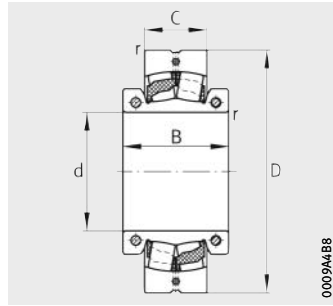


Non-locating bearing  
SNV

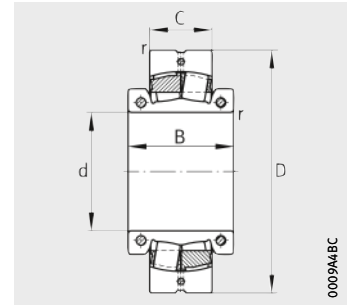
Fatigue limit load $C_{ur}$ N	Permissible axial load $F_a$ max. N	Limiting speed $n_G$ $\text{min}^{-1}$	Screw tightening torque		Replacement of unsplit spherical roller bearings with adapter sleeve		Suitable FAG plummer block housings
			$M_i$ Nm	$M_a$ Nm	Bearing	Adapter sleeve	
13 200	5 400	3 150	8	2	22212K	H312	SNV110
15 400	5 400	2 850	9	4	22213K	H313	SNV120
19 400	5 400	2 440	9	4	22215K	H315	SNV130
21 200	5 400	2 340	9	4	22216K	H316	SNV140
22 500	7 600	2 280	14	9	22217K	H317	SNV150
25 500	7 600	2 160	14	9	22218K	H318	SNV160
29 000	7 600	1 990	14	9	22219K	H319	SNV170
32 000	7 600	1 820	14	14	22220K	H320	SNV180
30 000	7 600	1 400	14	4	23122K	H3122	–
39 500	13 800	1 590	35	14	22222K	H322	SNV200
30 000	7 600	1 460	14	4	23024K	H3024	S3024-H
39 000	14 000	1 300	35	8	23124K	H3124	–
47 000	13 800	1 430	35	14	22224K	H3124	SNV215
35 000	7 600	1 390	14	9	23026K	H3026	S3026-H
49 000	7 600	1 200	14	4	23126K	H3126	–
53 000	13 800	1 290	35	14	22226K	H3126	SNV230
43 500	7 600	1 260	14	4	23028K	H3028	S3028-H
51 000	13 800	1 130	35	9	23128K	H3128	–
60 000	13 800	1 170	35	14	22228K	H3128	SNV250
45 500	13 800	1 200	35	9	23030K	H3030	S3030-H
56 000	22 200	1 060	69	14	23130K	H3130	–
74 000	22 200	1 090	69	35	22230K	H3130	SNV270
51 000	13 800	1 130	35	9	23032K	H3032	S3032-H
86 000	21 700	930	69	12	23132K	H3132	–
84 000	22 200	1 020	69	35	22232K	H3132	SNV290

# FAG spherical roller bearings

Split, metric sizes



Solid polyamide cage  
TVPA

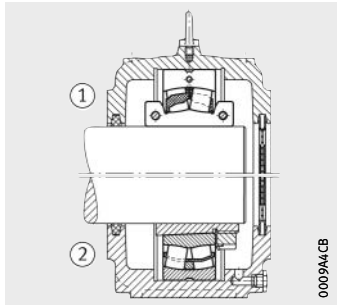


Solid brass cage  
MA

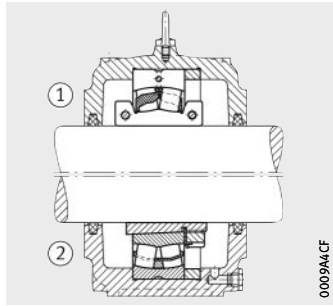
**Dimension table** (continued) - Dimensions in mm

Designation	Mass ≈ kg	Dimensions					Basic load ratings		Calculation factors			
		d	D	C	B	r min.	dyn. C <sub>r</sub> kN	stat. C <sub>0r</sub> kN	e	Y <sub>1</sub>	Y <sub>2</sub>	Y <sub>0</sub>
<b>230SM150-MA</b>	19,2	<b>150</b>	260	67	112	2,1	510	790	0,22	3,1	4,62	3,03
<b>231SM150-MA</b>	28	<b>150</b>	280	88	133	2,1	710	1 050	0,29	2,32	3,45	2,26
<b>222SM150-TVPA</b>	37,4	<b>150</b>	310	86	128	4	960	1 370	0,26	2,64	3,93	2,58
<b>230SM160-MA</b>	25,5	<b>160</b>	280	74	123	2,1	640	1 000	0,23	2,98	4,44	2,92
<b>231SM160-MA</b>	34,9	<b>160</b>	300	96	140	2,1	830	1 230	0,29	2,32	3,45	2,26
<b>222SM160-TVPA</b>	39,4	<b>160</b>	320	86	131	4	960	1 370	0,26	2,64	3,93	2,58
<b>230SM170-MA</b>	23,6	<b>170</b>	290	75	120	2,1	790	1 240	0,23	2,9	4,31	2,83
<b>231SM170-MA</b>	40,6	<b>170</b>	320	104	142	2,1	920	1 430	0,28	2,37	3,53	2,32
<b>222SM170-TVPA</b>	46,4	<b>170</b>	340	92	142	4	1 140	1 640	0,25	2,71	4,04	2,65
<b>230SM180-MA</b>	35	<b>180</b>	310	82	134	2,1	790	1 270	0,23	2,98	4,44	2,92
<b>231SM180-MA</b>	56,4	<b>180</b>	340	112	160	3	1 010	1 540	0,29	2,32	3,45	2,26
<b>222SM180-MA</b>	55,7	<b>180</b>	360	98	154	4	1 140	1 640	0,25	2,71	4,04	2,65
<b>230SM200-MA</b>	41,5	<b>200</b>	340	90	136	3	960	1 540	0,23	2,9	4,31	2,83
<b>231SM200-MA</b>	61,8	<b>200</b>	370	120	175	4	1 320	2 030	0,31	2,21	3,29	2,16
<b>222SM200-MA</b>	73,5	<b>200</b>	400	108	162	4	1 330	1 910	0,25	2,69	4	2,63
<b>230SM220-MA</b>	56,5	<b>220</b>	360	92	156	3	1 110	1 830	0,23	2,9	4,31	2,83
<b>231SM220-MA</b>	86	<b>220</b>	400	128	190	4	1 630	2 600	0,3	2,25	3,34	2,2
<b>222SM220-MA</b>	96,3	<b>220</b>	440	120	170	4	1 470	2 070	0,25	2,71	4,04	2,65
<b>230SM240-MA</b>	57,4	<b>240</b>	400	104	160	4	1 240	2 120	0,22	3,04	4,53	2,97
<b>231SM240-MA</b>	118	<b>240</b>	440	144	210	4	1 880	3 050	0,3	2,28	3,39	2,23
<b>222SM240-MA</b>	129	<b>240</b>	480	130	200	5	1 860	2 600	0,26	2,64	3,93	2,58
<b>230SM260-MA</b>	68	<b>260</b>	420	106	170	4	1 460	2 460	0,23	2,95	4,4	2,89
<b>231SM260-MA</b>	111	<b>260</b>	460	146	190	5	2 300	3 800	0,3	2,23	3,32	2,18
<b>222SM260-MA</b>	147	<b>260</b>	500	130	200	5	2 140	3 300	0,26	2,57	3,83	2,52
<b>230SM280-MA</b>	97	<b>280</b>	460	118	176	4	1 590	2 800	0,22	3,04	4,53	2,97
<b>231SM280-MA</b>	145	<b>280</b>	500	160	218	5	2 330	3 900	0,29	2,32	3,45	2,26
<b>222SM280-MA</b>	184	<b>280</b>	540	140	200	5	2 390	3 550	0,24	2,79	4,15	2,73

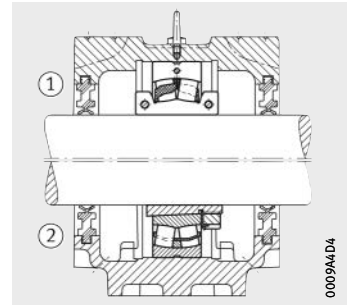
① Split spherical roller bearing. ② Unsplit spherical roller bearing.



Non-locating bearing  
S30



Locating bearing  
S30

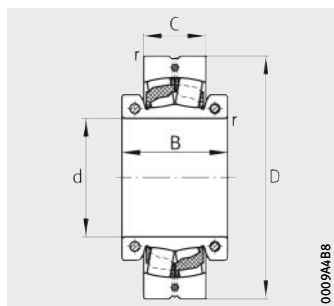


Non-locating bearing  
SNV

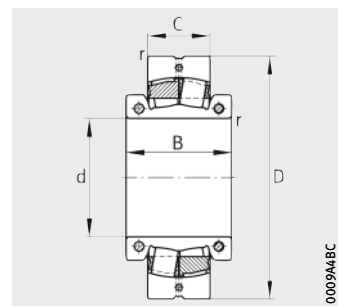
Fatigue limit load $C_{ur}$ N	Permissible axial load $F_a$ max. N	Limiting speed $n_G$ $\text{min}^{-1}$	Screw tightening torque		Replacement of unsplit spherical roller bearings with adapter sleeve		Suitable FAG plummer block housings
			$M_i$ Nm	$M_a$ Nm	Bearing	Adapter sleeve	
57 000	13 800	1 060	35	9	23034K	H3034	S3034-H
86 000	22 000	930	69	35	23134K	H3134	SNS3134-H-D
94 000	22 200	940	69	35	22234K	H3134	–
95 000	22 200	970	69	14	23036K	H3036	SNS3036-H-D
98 000	22 000	870	69	35	23136K	H3136	SNS3136-H-D
94 000	22 200	940	69	35	22236K	H3136	–
112 000	22 200	900	69	14	23038K	H3038	SNS3038-H-D
113 000	22 000	830	69	35	23138K	H3138	SNS3138-H-D
112 000	22 200	860	69	35	22238K	H3138	–
114 000	22 000	870	69	14	23040K	H3040	SNS3040-H-D
118 000	22 000	780	69	35	23140K	H3140	SNS3140-H-D
104 000	22 200	790	69	35	22240K	H3140	–
134 000	22 200	820	69	35	23044K	H3044X	SNS3044-H-D
149 000	32 000	690	120	69	23144K	H3144X	SNS3144-H-D
121 000	32 000	760	120	69	22244K	H3144X	–
151 000	32 000	730	120	35	23048K	H3048	SNS3048-H-D
189 000	32 000	640	120	69	23148K	H3148X	SNS3148-H-D
127 000	32 000	680	120	69	22248K	H3148X	–
175 000	32 000	690	120	69	23052K	H3052X	SNS3052-H-D
216 000	32 000	580	120	69	23152K	H3152X	SNS3152-H-D
157 000	60 000	620	295	120	22252K	H3152X	–
198 000	32 000	620	120	35	23056K	H3056	SNS3056-H-D
255 000	32 000	510	120	35	23156K	H3156X	SNS3156-H-D
206 000	60 000	600	295	69	22256K	H3156X	–
226 000	32 000	590	120	69	23060K	H3060	SNS3060-H-D
260 000	44 000	485	190	120	23160K	H3160	SNS3160-H-D
212 000	60 000	540	295	120	22260K	H3160	–

# FAG spherical roller bearings

Split, metric sizes



Solid polyamide cage  
TVPA

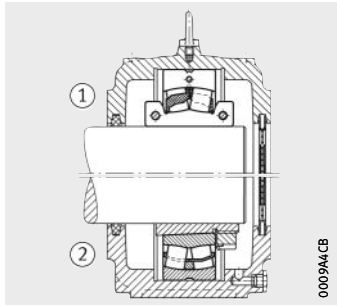


Solid brass cage  
MA

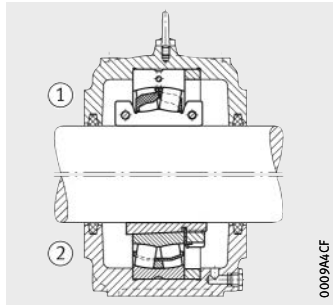
**Dimension table** (continued) - Dimensions in mm

Designation	Mass  ≈ kg	Dimensions					Basic load ratings		Calculation factors			
		d	D	C	B	r min.	dyn. C <sub>r</sub> kN	stat. C <sub>0r</sub> kN	e	Y <sub>1</sub>	Y <sub>2</sub>	Y <sub>0</sub>
<b>230SM300-MA</b>	108	<b>300</b>	480	121	186	4	1 870	3 200	0,23	2,9	4,31	2,83
<b>231SM300-MA</b>	184	<b>300</b>	540	176	225	5	2 750	4 700	0,29	2,3	3,42	2,25
<b>222SM300-MA</b>	214	<b>300</b>	580	150	212	5	2 650	4 050	0,24	2,84	4,23	2,78
<b>230SM320-MA</b>	132	<b>320</b>	520	133	200	5	2 060	3 650	0,22	3,04	4,53	2,97
<b>231SM320-MA</b>	226	<b>320</b>	580	190	258	5	3 100	5 200	0,3	2,26	3,37	2,21
<b>222SM320-MA</b>	249	<b>320</b>	620	165	230	6	3 100	4 750	0,24	2,76	4,11	2,7
<b>230SM340-MA</b>	157	<b>340</b>	540	134	205	5	2 380	4 150	0,22	3,01	4,48	2,94
<b>231SM340-MA</b>	314	<b>340</b>	600	192	270	5	3 900	6 800	0,3	2,25	3,34	2,2
<b>222SM340-MA</b>	276	<b>340</b>	650	170	240	6	3 450	5 100	0,25	2,69	4	2,63
<b>230SM360-MA</b>	154	<b>360</b>	560	135	218	5	2 550	4 600	0,22	3,1	4,62	3,03
<b>231SM360-MA</b>	292	<b>360</b>	620	194	270	5	3 900	6 900	0,3	2,28	3,39	2,23
<b>230SM380-MA</b>	204	<b>380</b>	600	148	225	5	2 750	5 100	0,21	3,2	4,77	3,13
<b>231SM380-MA</b>	385	<b>380</b>	650	200	270	6	4 100	7 200	0,28	2,39	3,56	2,34
<b>230SM400-MA</b>	214	<b>400</b>	620	150	225	5	3 100	5 700	0,22	3,1	4,62	3,03
<b>240SM400-MA</b>	313	<b>400</b>	620	200	290	5	3 700	7 900	0,32	2,13	3,17	2,08
<b>231SM400-MA</b>	417	<b>400</b>	700	224	300	6	4 350	7 700	0,28	2,39	3,56	2,34
<b>230SM410-MA</b>	222	<b>410</b>	650	157	225	5	3 150	5 800	0,21	3,2	4,77	3,13
<b>231SM410-MA</b>	566	<b>410</b>	720	226	315	6	5 400	9 700	0,29	2,3	3,42	2,25
<b>230SM420-MA</b>	246	<b>420</b>	650	157	235	5	3 150	5 800	0,21	3,2	4,77	3,13
<b>231SM430-MA</b>	627	<b>430</b>	760	240	344	6	5 500	10 400	0,29	2,33	3,47	2,28
<b>230SM450-MA</b>	291	<b>450</b>	700	165	245	6	3 650	6 900	0,21	3,2	4,77	3,13
<b>230SM470-MA</b>	354	<b>470</b>	720	167	260	6	3 600	7 500	0,23	2,9	4,31	2,83
<b>241SM470-MA</b>	872	<b>470</b>	830	325	420	7,5	7 700	15 500	0,39	1,75	2,61	1,71
<b>230SM500-MA</b>	427	<b>500</b>	780	185	270	6	4 200	8 400	0,2	3,34	4,98	3,27
<b>241SM500-MA</b>	1 100	<b>500</b>	870	335	450	7,5	8 400	17 600	0,39	1,73	2,58	1,69
<b>239SM530-MA</b>	293	<b>530</b>	750	140	225	5	2 750	6 500	0,18	3,85	5,73	3,76
<b>230SM530-MA</b>	555	<b>530</b>	820	195	300	6	4 900	10 500	0,23	2,95	4,4	2,89
<b>241SM530-MA</b>	1 360	<b>530</b>	920	355	500	7,5	9 100	19 200	0,38	1,77	2,64	1,73
<b>239SM560-MA</b>	356	<b>560</b>	800	150	235	5	2 950	7 000	0,17	3,95	5,88	3,86
<b>239SM600-MA</b>	410	<b>600</b>	850	165	250	5	3 850	8 800	0,18	3,66	5,46	3,58
<b>230SM630-MA</b>	955	<b>630</b>	980	230	355	7,5	6 400	13 700	0,22	3,01	4,48	2,94

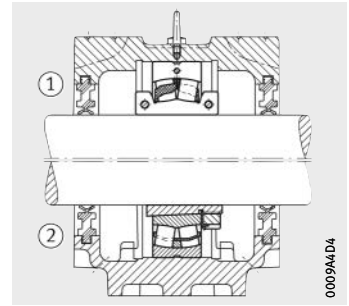
① Split spherical roller bearing. ② Unsplit spherical roller bearing.



Non-locating bearing  
S30



Locating bearing  
S30

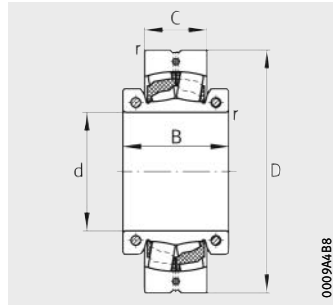


Non-locating bearing  
SNV

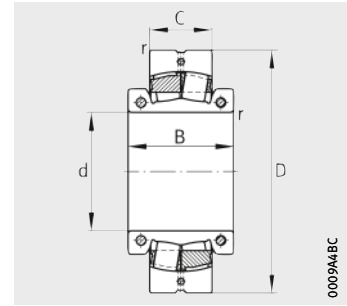
Fatigue limit load $C_{ur}$ N	Permissible axial load $F_a$ max. N	Limiting speed $n_G$ $\text{min}^{-1}$	Screw tightening torque		Replacement of unsplit spherical roller bearings with adapter sleeve		Suitable FAG plummer block housings
			$M_i$ Nm	$M_a$ Nm	Bearing	Adapter sleeve	
250 000	32 000	530	120	69	23064K	H3064-HG	SNS3064-H-D
300 000	60 000	435	295	120	23164K	H3164-HG	SNS3164-H-D
229 000	60 000	480	295	120	22264K	H3164-HG	–
285 000	60 000	500	295	69	23068K	H3068-HG	SNS3068-H-D
320 000	60 000	400	295	190	23168K	H3168-HG	SNS3168-H-D
270 000	60 000	450	295	120	22268K	H3168-HG	–
310 000	60 000	450	295	69	23072K	H3072-HG	SNS3072-H-D
410 000	60 000	360	295	35	23172K	H3172-HG	SNS3172-H-D
285 000	60 000	415	295	120	22272K	H3172-HG	–
345 000	60 000	435	295	69	23076K	H3076-HG	SNS3076-H-D
415 000	60 000	350	295	69	23176K	H3176-HG	SNS3176-H-D
350 000	60 000	420	295	120	23080K	H3080-HG	SNS3080-H-D
435 000	60 000	340	295	120	23180K	H3180-HG	SNS3180-H-D
415 000	60 000	385	295	69	23084K	H3084X-HG	SNS3084-H-D
620 000	60 000	310	295	69	24084K	H24084-HG	–
475 000	60 000	325	295	190	23184K	H3184-HG	SNS3184-H-D
420 000	60 000	370	295	120	23088K	H3088-HG	SNS3088-H-D
560 000	60 000	295	295	120	23188K	H3188-HG	SNS3188-H-D
420 000	60 500	370	295	120	23088K	AHX3088G-H	–
590 000	94 200	280	580	190	23192K	H3192-HG	–
490 000	60 000	335	190	69	23096K	H3096-HG	–
425 000	60 000	325	295	120	230/500K	H30/500-HG	–
1 020 000	60 000	224	1 000	295	241/500K	H241/500-HG	–
580 000	60 000	310	295	120	230/530K	H30/530-HG	–
1 280 000	60 000	207	1 000	295	241/530K	H241/530-HG	–
365 000	60 000	325	295	69	239/560K	H39/560-HG	–
670 000	94 200	265	580	120	230/560K	H30/560-HG	–
1 370 000	135 300	197	2 000	295	241/560K	H241/560-HG	–
530 000	60 000	305	295	69	239/600K	H39/600-HG	–
540 000	60 000	280	295	69	239/630K	H39/630-HG	–
950 000	94 200	219	1 000	120	230/670K	H30/670-HG	–

# FAG spherical roller bearings

Split, inch sizes



Solid polyamide cage  
TVPA



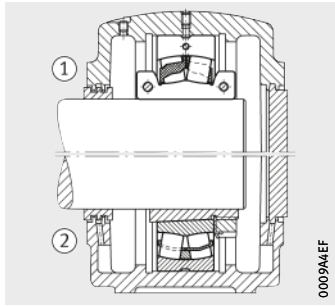
Solid brass cage  
MA

Dimension table · Dimensions in mm

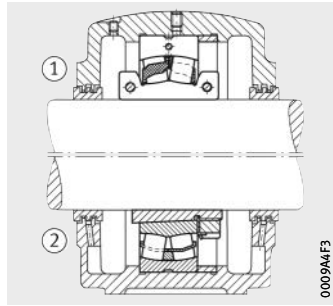
Designation	Mass ≈ kg	Dimensions						Basic load ratings		Calculation factors			
		d		D	C	B	r min.	dyn. C <sub>r</sub> kN	stat. C <sub>0r</sub> kN	e	Y <sub>1</sub>	Y <sub>2</sub>	Y <sub>0</sub>
		inch	mm										
222S.203	2,25	2 <sup>3</sup> / <sub>16</sub>	55,563	120	31	55	1,5	136	155	0,23	2,98	4,44	2,92
222S.204	2,19	2 <sup>1</sup> / <sub>4</sub>	57,15	120	31	55	1,5	136	155	0,23	2,98	4,44	2,92
222S.207	2,81	2 <sup>7</sup> / <sub>16</sub>	61,913	130	31	60	1,5	172	210	0,24	2,81	4,19	2,75
222S.208	2,47	2 <sup>1</sup> / <sub>2</sub>	63,5	130	31	60	1,5	172	210	0,24	2,81	4,19	2,75
222S.211	3,27	2 <sup>11</sup> / <sub>16</sub>	68,263	140	33	62	2	180	226	0,23	2,95	4,4	2,89
222S.215	3,94	2 <sup>15</sup> / <sub>16</sub>	74,613	150	36	68	2	184	237	0,22	3,1	4,62	3,03
222S.300	3,88	3	76,2	150	36	68	2	184	237	0,22	3,1	4,62	3,03
222S.303	4,27	3 <sup>3</sup> / <sub>16</sub>	80,963	160	40	70	2	213	270	0,22	3,14	4,67	3,07
222S.304	4,22	3 <sup>1</sup> / <sub>4</sub>	82,55	160	40	70	2	213	270	0,22	3,14	4,67	3,07
222S.307	6,86	3 <sup>7</sup> / <sub>16</sub>	87,313	180	46	76	2,1	285	360	0,23	2,9	4,31	2,83
222S.307-MA	6,98	3 <sup>7</sup> / <sub>16</sub>	87,313	180	46	76	2,1	265	320	0,23	2,9	4,31	2,83
222S.308	6,77	3 <sup>1</sup> / <sub>2</sub>	88,9	180	46	76	2,1	285	360	0,23	2,9	4,31	2,83
222S.308-MA	6,86	3 <sup>1</sup> / <sub>2</sub>	88,9	180	46	76	2,1	265	320	0,23	2,9	4,31	2,83
222S.315	10,1	3 <sup>15</sup> / <sub>16</sub>	100,013	200	53	92	2,1	360	460	0,24	2,84	4,23	2,78
222S.400	9,93	4	101,6	200	53	92	2,1	360	460	0,24	2,84	4,23	2,78
222S.403	11,7	4 <sup>3</sup> / <sub>16</sub>	106,363	215	58	98	2,1	460	590	0,25	2,71	4,04	2,65
222S.407	15,2	4 <sup>7</sup> / <sub>16</sub>	112,713	230	64	104	3	540	720	0,25	2,71	4,04	2,65
222S.408	15,1	4 <sup>1</sup> / <sub>2</sub>	114,3	230	64	104	3	540	720	0,25	2,71	4,04	2,65
222S.415	18	4 <sup>15</sup> / <sub>16</sub>	125,413	250	68	110	3	630	870	0,26	2,62	3,9	2,56
222S.415-MA	17,5	4 <sup>15</sup> / <sub>16</sub>	125,413	250	68	110	3	580	780	0,26	2,62	3,9	2,56
222S.500	19	5	127	250	68	110	3	630	870	0,26	2,62	3,9	2,56
222S.503	25,3	5 <sup>3</sup> / <sub>16</sub>	131,763	270	73	122	3	730	1020	0,25	2,67	3,97	2,61
222S.507	30	5 <sup>7</sup> / <sub>16</sub>	138,113	290	80	124	3	850	1190	0,25	2,69	4	2,63
222S.507-MA	31,1	5 <sup>7</sup> / <sub>16</sub>	138,113	290	80	124	3	780	1060	0,25	2,69	4	2,63
222S.508	29,8	5 <sup>1</sup> / <sub>2</sub>	139,7	290	80	124	3	850	1190	0,25	2,69	4	2,63
230S.508-MA	13,7	5 <sup>1</sup> / <sub>2</sub>	139,7	240	60	106	2,1	445	690	0,22	3,1	4,62	3,03

① Split spherical roller bearing. ② Unsplit spherical roller bearing.

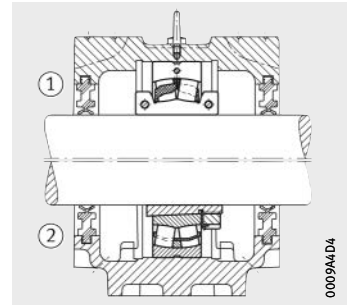




Non-locating bearing  
SAF



Locating bearing  
SAF

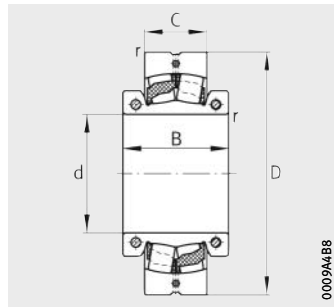


Non-locating bearing  
SNV

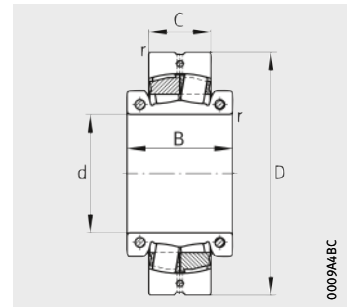
Fatigue limit load $C_{ur}$ N	Permissible axial load $F_a$ max. N	Limiting speed $n_G$ $\text{min}^{-1}$	Screw tightening torque		Replacement of unsplit spherical roller bearings with adapter sleeve			Suitable FAG plummer block housings	
			$M_i$ Nm	$M_a$ Nm	Bearing	Adapter sleeve			
15 400	5 400	2 850	9	4	22213K	SNW13X0203	H313X203	SAF513	SNV120
15 400	5 400	2 850	9	4	22213K	SNW13X0204	H313X204	SAF513/2.1/4	SNV120
19 400	5 400	2 440	9	4	22215K	SNW15X0207	H315X207	SAF515	SNV130
19 400	5 400	2 440	9	4	22215K	SNW15X0208	H315X208	SAF515/2.1/2	SNV130
21 200	5 400	2 340	9	4	22216K	SNW16X0211	H316X211	SAF516	SNV140
22 500	7 600	2 280	14	9	22217K	SNW17X0215	H317X215	SAF517	SNV150
22 500	7 600	2 280	14	9	22217K	SNW17X0300	H317X300	SAF517/3	SNV150
25 500	7 600	2 160	14	9	22218K	SNW18X0303	H318X303	SAF518	SNV160
25 500	7 600	2 160	14	9	22218K	SNW18X0304	H318X304	SAF518/3.1/4	SNV160
32 000	7 600	1 820	14	14	22220K	SNW20X0307	H320X307	SAF520	SNV180
28 500	7 600	1 820	14	14	22220K	SNW20X0307	H320X307	SAF520	SNV180
32 000	7 600	1 820	14	14	22220K	SNW20X0308	H320X308	SAF520/3.1/2	SNV180
28 500	7 600	1 820	14	14	22220K	SNW20X0308	H320X308	SAF520/3.1/2	SNV180
39 500	13 800	1 590	35	14	22222K	SNW22X0315	H322X315	SAF522	SNV200
39 500	13 800	1 590	35	14	22222K	SNW22X0400	H322X400	SAF522/4	SNV200
47 000	13 800	1 430	35	14	22224K	SNW24X0403	H3124X403	SAF524	SNV215
53 000	13 800	1 290	35	14	22226K	SNW26X0407	H3126X407	SAF526	SNV230
53 000	13 800	1 290	35	14	22226K	SNW26X0408	H3126X408	SAF526/4.1/2	SNV230
60 000	14 000	1 170	35	14	22228K	SNW28X0415	H3128X415	SAF528	SNV250
53 000	13 800	1 170	35	14	22228K	SNW28X0415	H3128X415	SAF528	SNV250
60 000	13 800	1 170	35	14	22228K	SNW28X0500	H3128X500	SAF528/5	SNV250
74 000	22 200	1 090	69	35	22230K	SNW30X0503	H3130X503	SAF530	SNV270
84 000	22 200	1 020	69	35	22232K	SNW32X0507	H3132X507	SAF532	SNV290
74 000	22 200	1 020	69	35	22232K	SNW32X0507	H3132X507	SAF532	SNV290
84 000	22 200	1 020	69	35	22232K	SNW32X0508	H3132X508	SAF532/5.1/2	SNV290
51 000	13 800	1 130	35	9	23032K	SNP3032X0508	H3032X508	SAF032K/5.1/2	–

# FAG spherical roller bearings

Split, inch sizes



Solid polyamide cage  
TVPA

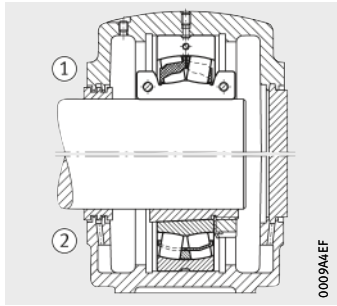


Solid brass cage  
MA

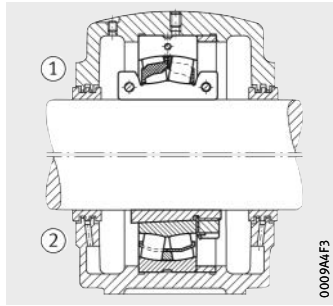
**Dimension table** (continued) - Dimensions in mm

Designation	Mass ≈ kg	Dimensions						Basic load ratings		Calculation factors			
		d		D	C	B	r min.	dyn. C <sub>r</sub> kN	stat. C <sub>0r</sub> kN	e	Y <sub>1</sub>	Y <sub>2</sub>	Y <sub>0</sub>
		inch	mm										
<b>222S.515</b>	36	<b>5<sup>15</sup>/<sub>16</sub></b>	<b>150,813</b>	310	86	128	4	960	1 370	0,26	2,64	3,93	2,58
<b>222S.600</b>	36,9	<b>6</b>	<b>152,4</b>	310	86	128	4	960	1 370	0,26	2,64	3,93	2,58
<b>222S.607</b>	38,5	<b>6<sup>7</sup>/<sub>16</sub></b>	<b>163,513</b>	320	86	131	4	960	1 370	0,26	2,64	3,93	2,58
<b>230S.607-MA</b>	24,4	<b>6<sup>7</sup>/<sub>16</sub></b>	<b>163,513</b>	280	74	123	2,1	640	1 000	0,23	2,98	4,44	2,92
<b>231S.607</b>	34,8	<b>6<sup>7</sup>/<sub>16</sub></b>	<b>163,513</b>	300	96	140	2,1	830	1 230	0,29	2,32	3,45	2,26
<b>222S.608</b>	38,1	<b>6<sup>1</sup>/<sub>2</sub></b>	<b>165,1</b>	320	86	131	4	960	1 370	0,26	2,64	3,93	2,58
<b>222S.615</b>	44,2	<b>6<sup>15</sup>/<sub>16</sub></b>	<b>176,213</b>	340	92	142	4	1 140	1 640	0,25	2,71	4,04	2,65
<b>231S.615</b>	41,7	<b>6<sup>15</sup>/<sub>16</sub></b>	<b>176,213</b>	320	104	142	2,1	920	1 430	0,28	2,37	3,53	2,32
<b>230S.700</b>	21,1	<b>7</b>	<b>177,8</b>	290	75	120	2,1	790	1 240	0,23	2,9	4,31	2,83
<b>231S.700</b>	61,8	<b>7</b>	<b>177,8</b>	340	112	150	3	1 010	1 540	0,29	2,32	3,45	2,26
<b>222S.703</b>	59	<b>7<sup>3</sup>/<sub>16</sub></b>	<b>182,563</b>	360	98	154	4	1 140	1 640	0,25	2,71	4,04	2,65
<b>231S.703</b>	50,8	<b>7<sup>3</sup>/<sub>16</sub></b>	<b>182,563</b>	340	112	160	3	1 010	1 540	0,29	2,32	3,45	2,26
<b>222S.708</b>	76,8	<b>7<sup>1</sup>/<sub>2</sub></b>	<b>190,5</b>	400	108	162	4	1 330	1 910	0,25	2,69	4	2,63
<b>222S.715</b>	75,4	<b>7<sup>15</sup>/<sub>16</sub></b>	<b>201,613</b>	400	108	162	4	1 330	1 910	0,25	2,69	4	2,63
<b>231S.715</b>	72,6	<b>7<sup>15</sup>/<sub>16</sub></b>	<b>201,613</b>	370	120	175	4	1 320	2 030	0,31	2,21	3,29	2,16
<b>222S.800</b>	74,7	<b>8</b>	<b>203,2</b>	400	108	162	4	1 330	1 910	0,25	2,69	4	2,63
<b>230S.807</b>	58,9	<b>8<sup>7</sup>/<sub>16</sub></b>	<b>214,313</b>	360	92	156	3	1 110	1 830	0,23	2,9	4,31	2,83
<b>230S.808</b>	58,9	<b>8<sup>1</sup>/<sub>2</sub></b>	<b>215,9</b>	360	92	156	3	1 110	1 830	0,23	2,9	4,31	2,83
<b>230S.900</b>	52,8	<b>9</b>	<b>228,6</b>	360	92	160	3	1 110	1 830	0,23	2,9	4,31	2,83
<b>231S.907</b>	127	<b>9<sup>7</sup>/<sub>16</sub></b>	<b>239,713</b>	440	144	210	4	1 880	3 050	0,3	2,28	3,39	2,23
<b>230S.908</b>	56,8	<b>9<sup>1</sup>/<sub>2</sub></b>	<b>241,3</b>	400	104	160	4	1 240	2 120	0,22	3,04	4,53	2,97
<b>231S.908</b>	112	<b>9<sup>1</sup>/<sub>2</sub></b>	<b>241,3</b>	440	144	210	4	1 880	3 050	0,3	2,28	3,39	2,23
<b>231S.915</b>	116	<b>9<sup>15</sup>/<sub>16</sub></b>	<b>252,413</b>	460	146	190	5	2 300	3 800	0,3	2,23	3,32	2,18
<b>230S.1000</b>	71,2	<b>10</b>	<b>254</b>	420	106	170	4	1 460	2 460	0,23	2,95	4,4	2,89
<b>231S.1000</b>	123	<b>10</b>	<b>254</b>	460	146	190	5	2 300	3 800	0,3	2,23	3,32	2,18
<b>231S.1007</b>	116	<b>10<sup>7</sup>/<sub>16</sub></b>	<b>265,113</b>	460	146	190	5	2 300	3 800	0,3	2,23	3,32	2,18
<b>230S.1008</b>	64,3	<b>10<sup>1</sup>/<sub>2</sub></b>	<b>266,7</b>	420	106	170	4	1 460	2 460	0,23	2,95	4,4	2,89
<b>231S.1015</b>	145	<b>10<sup>15</sup>/<sub>16</sub></b>	<b>277,812</b>	500	160	218	5	2 330	3 900	0,29	2,32	3,45	2,26
<b>230S.1100</b>	91,7	<b>11</b>	<b>279,4</b>	460	118	176	4	1 590	2 800	0,22	3,04	4,53	2,97
<b>231S.1100</b>	150	<b>11</b>	<b>279,4</b>	500	160	218	5	2 330	3 900	0,29	2,32	3,45	2,26

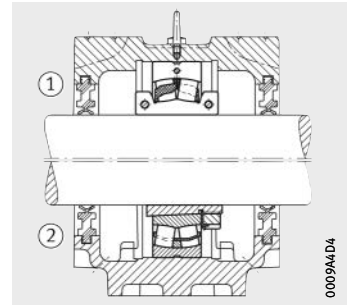
① Split spherical roller bearing. ② Unsplit spherical roller bearing.



Non-locating bearing  
SAF



Locating bearing  
SAF

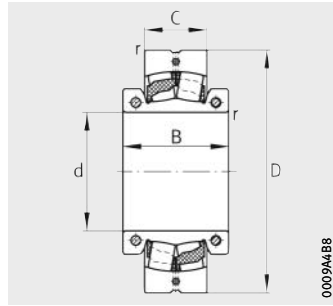


Non-locating bearing  
SNV

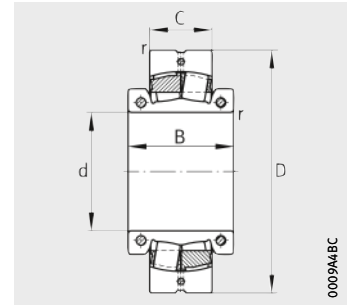
Fatigue limit load $C_{ur}$ N	Permissible axial load $F_a$ max. N	Limiting speed $n_G$ $\text{min}^{-1}$	Screw tightening torque		Replacement of unsplit spherical roller bearings with adapter sleeve			Suitable FAG plummer block housings
			$M_i$ Nm	$M_a$ Nm	Bearing	Adapter sleeve		
94 000	22 200	940	69	35	22234K	H3134X515	SNW34X0515	SAF534
94 000	22 200	940	69	35	22234K	H3134X600	SNW34X0600	SAF534/6
94 000	22 200	940	69	35	22236K	H3136X607	SNW36X0607	SAF536
95 000	22 200	970	69	14	23038K	H3036X607	SNP3036X0607	SAF036K/6.7/16
98 000	22 000	870	69	35	23136K	H3136X607	SNW3136X0607	SDAF3136K6.7/16
94 000	22 200	940	69	35	22236K	H3136X608	SNW36X0608	SAF536/6.1/2
112 000	22 200	860	69	35	22238K	H3138X615	SNW38X0615	SAF538
113 000	22 000	830	69	35	23138K	H3138X615	SNW3138X0615	SDAF3138K/6.15/16
112 000	22 200	900	69	14	23038K	H3038X700	SNP3038X0700	SAF038K/7
118 000	22 000	780	69	35	23140K	H3138X700	SNW3138X0700	SDAF3140K/7
104 000	22 200	790	69	35	22240K	H3140X703	SNW40X0703	SAF540
118 000	22 000	780	69	35	23140K	H3140X703	SNW3140X0703	SDAF3140K/7.3/16
121 000	32 000	760	120	69	22244K	H3144XX708	SNW44X0708	SAF544/7.1/2
121 000	32 000	760	120	69	22244K	H3144XX715	SNW44X0715	SAF544
149 000	32 000	690	120	69	23144K	H3144XX715	SNW3144X0715	SDAF3144K/7.15/16
121 000	32 000	760	120	69	22244K	H3144XX800	SNW44X0800	SAF544/8
151 000	32 000	730	120	35	23048K	H3048X807	SNP3048X0807	SAF048K/8.7/16
151 000	32 000	730	120	35	23048K	H3048X808	SNP3048X0808	SAF048K/8.1/2
151 000	32 000	730	120	35	23048K	H3052XX900	SNP3048X0900	SAF048K/9
216 000	32 000	580	120	69	23152K	H3152XX907	SNP3152X0907	SDAF3152K/9.7/16
175 000	32 000	690	120	69	23052K	H3052XX908	SNP3052X0908	SAF052K/9.1/2
216 000	32 000	580	120	69	23152K	H3152XX908	SNP3152X0908	SDAF3152K/9.1/2
255 000	32 000	510	120	35	23156K	H3156XX915	SNP3156X0915	SDAF3156K/9.15/16
198 000	32 000	620	120	35	23056K	H3056X1000	SNP3056X1000	SAF056K/10
255 000	32 000	510	120	35	23156K	H3156XX1000	SNP3156X1000	SDAF3156K/10
255 000	32 000	510	120	35	23156K	H3156XX1007	SNP3156X1007	SDAF3156K/10.7/16
198 000	32 000	620	120	35	23056K	H3056X1008	SNP3056X1008	SAF056K/10.1/2
260 000	44 000	485	190	120	23160K	H3160X1015	SNP3160X1015	SDAF3160K/10.15/16
226 000	32 000	590	120	69	23060K	H3060X1100	SNP3060X1100	SDAF060K/11
260 000	44 000	485	190	120	23160K	H3160X1100	SNP3160X1100	SDAF3160K/11

# FAG spherical roller bearings

Split, inch sizes



Solid polyamide cage  
TVPA

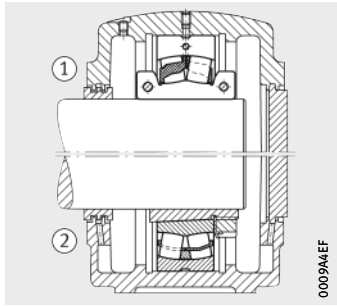


Solid brass cage  
MA

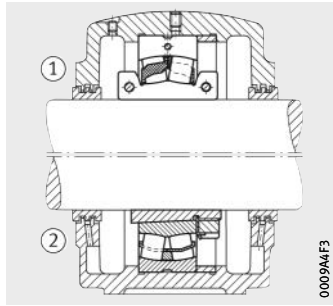
**Dimension table** (continued) - Dimensions in mm

Designation	Mass ≈ kg	Dimensions						Basic load ratings		Calculation factors			
		d		D	C	B	r min.	dyn. C <sub>r</sub> kN	stat. C <sub>0r</sub> kN	e	Y <sub>1</sub>	Y <sub>2</sub>	Y <sub>0</sub>
		inch	mm										
<b>230S.1200</b>	96,5	<b>12</b>	<b>304,8</b>	480	121	186	4	1 870	3 200	0,23	2,9	4,31	2,83
<b>231S.1200</b>	182	<b>12</b>	<b>304,8</b>	540	176	225	5	2 750	4 700	0,29	2,3	3,42	2,25
<b>231S.1207</b>	280	<b>12<sup>7/16</sup></b>	<b>315,913</b>	580	190	258	5	3 100	5 200	0,3	2,26	3,37	2,21
<b>231S.1208</b>	226	<b>12<sup>1/2</sup></b>	<b>317,5</b>	580	190	258	5	3 100	5 200	0,3	2,26	3,37	2,21
<b>230S.1300</b>	165	<b>13</b>	<b>330,2</b>	540	134	205	5	2 380	4 150	0,22	3,01	4,48	2,94
<b>231S.1300</b>	288	<b>13</b>	<b>330,2</b>	600	192	270	5	3 900	6 800	0,3	2,25	3,34	2,2
<b>231S.1308</b>	314	<b>13<sup>1/2</sup></b>	<b>342,9</b>	600	192	270	5	3 900	6 800	0,3	2,25	3,34	2,2
<b>230S.1400</b>	158	<b>14</b>	<b>355,6</b>	560	135	218	5	2 550	4 600	0,22	3,1	4,62	3,03
<b>231S.1400</b>	273	<b>14</b>	<b>355,6</b>	620	194	270	5	3 900	6 900	0,3	2,28	3,39	2,23
<b>230S.1500</b>	192	<b>15</b>	<b>381</b>	600	148	225	5	2 750	5 100	0,21	3,2	4,77	3,13
<b>230S.1600</b>	225	<b>16</b>	<b>406,4</b>	650	157	225	5	3 150	5 800	0,21	3,2	4,77	3,13

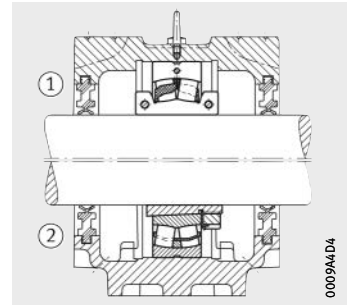
① Split spherical roller bearing. ② Unsplit spherical roller bearing.



Non-locating bearing  
SAF



Locating bearing  
SAF



Non-locating bearing  
SNV

Fatigue limit load $C_{ur}$ N	Permissible axial load $F_a$ max. N	Limiting speed $n_G$ $\text{min}^{-1}$	Screw tightening torque		Replacement of unsplit spherical roller bearings with adapter sleeve			Suitable FAG plummer block housings
			$M_i$ Nm	$M_a$ Nm	Bearing	Adapter sleeve		
250 000	32 000	530	120	69	23064K	H3064-HGX1200	SNP3064X1200	SDAF064K/12
300 000	60 000	435	295	120	23164K	H3168-HGX1200	SNP3164X1200	SDAF3164K/12
320 000	60 000	400	295	190	23168K	H3168-HGX1207	SNP3168X1207	SDAF3168K12.7/16
320 000	60 000	400	295	190	23168K	H3168-HGX1208	SNP3168X1208	SDAF3168K/12.1/2
310 000	60 000	450	295	69	23072K	H3072-HGX1300	SNP3072X1300	SDAF072K/13
405 000	60 000	360	295	35	23172K	H3172-HGX1300	SNP3172X1300	SDAF3172K/13
410 000	60 000	360	295	35	23172K	H3172-HGX1308	SNP3172X1308	SDAF3172K/13.1/2
345 000	60 000	435	295	69	23076K	H3076-HGX1400	SNP3076X1400	SDAF076K/14
415 000	60 000	350	295	35	23176K	H3176-HGX1400	SNP3176X1400	SDAF3176K/14
350 000	60 000	420	295	120	23080K	H3080-HGX1500	SNP3080X1500	SDAF080K/15
420 000	60 000	370	295	120	23088K	H3088-HGX1600	SNP3088X1600	SDAF088K/16

## Distribuidor Autorizado:



**Rolamentos CBF Ltda.**  
**Tel +55 11 3824-6400**  
**E-mail: vendas@cbfcorp.com.br**  
**www.rolamentoscbf.com.br**

### **Schaeffler Technologies AG & Co. KG**

Georg-Schäfer-Straße 30  
97421 Schweinfurt  
Germany  
Internet [www.schaeffler.de/en](http://www.schaeffler.de/en)  
E-mail [faginfo@schaeffler.com](mailto:faginfo@schaeffler.com)

In Germany:

Phone 0180 5003872  
Fax 0180 5003873

From other countries:

Phone +49 9721 91-0  
Fax +49 9721 91-3435

Every care has been taken to ensure the correctness of the information contained in this publication but no liability can be accepted for any errors or omissions. We reserve the right to make technical changes.

© Schaeffler Technologies AG & Co. KG

Issued: 2017, August

This publication or parts thereof may not be reproduced without our permission.

TPI 250 GB-D