

MERKEL RADIAMATIC RPM 41

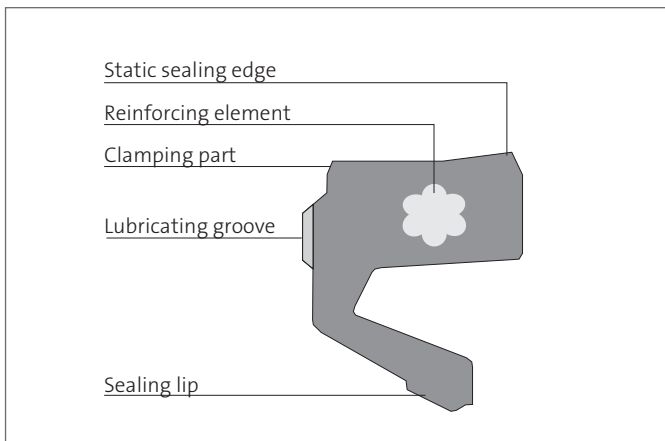

Merkel Radiamatic RPM 41 is a radial shaft seal made of an elastomer material with an embedded steel body featuring radial and circumferential lubricating grooves for twin arrangement.



VALUE TO THE CUSTOMER

- Wide range of customized sizes of standard profiles
- Fast delivery for quick maintenance needs – within 24 hours, if needed
- Self-retaining with a secure press fit
- Suitable for open and cover plated housings
- Rubber at outer diameter for easy mounting or demounting and to prevent housing damage
- No exposed corroding components
- Without tension spring at sealing lip

Applications

Self-retaining rotary shaft seal typically used for sealing roller bearings in steel mills.

Material

Material	Designation
Nitrile rubber	85 NBR 245461

Operating conditions

Medium/Condition	NBR
Lubricating grease	-30 ... +100 °C
Rolling oil emulsion	on request
Pressure $\varnothing D \leq 700$ mm	0,05 MPa
Pressure $\varnothing D > 700$ mm	0,03 MPa
Sliding speed	15 m/s

The figures given are maximum values and must not be applied simultaneously.



FEATURES AND BENEFITS

Functional description

The Merkel Radiamatic RPM 41 is a tailor-made sealing element optimized by using FEM, and is made from an elastomer material developed specifically for this application. The sealing lip, manufactured from pure elastomer, does not require any spring support, and excels in terms of minimized friction coupled with a maximized sealing effect. The clamping part features radial and circumferential grooves, to enable additional lubrication to be provided from outside.

The press fit in the housing is assured by a reinforcing element integrated into the clamping body. Any damage to the housing is thus precluded. The Radiamatic RPM 41 – produced as an endless ring or as a jointed version – can be inserted in open housings or in housings with axial flanges or in axially chambered housings.

Surface finish

Roughness	R_a	R_{max}
Sliding surface	$\leq 0,6 \mu m$	$\leq 2,5 \mu m$
Housing	3,2 ... 6,3 μm	16 ... 25 μm

The running surface is best machined by grinding in plunging mode, i. e. without feeding. The surface hardness shall be approx. 60 HRC (hardening depth min. 0,5 mm).

With rising circumferential velocity, the counter surface should be manufactured with a decreasing roughness R_a . For adequate formation of a lubricating film, the surface should not become too smooth.

Recommended value: $R_a \text{ min.} = 0,1 \mu m$.

Profile bearing length ratio $M_r > 50\%$ to max. 90% with cutting depth $c = R_a/2$ and reference line $C_{ref} = 0\%$. Abrasive surfaces, scoring, scratches and cavities must all be avoided.

Tolerances

D	Tolerance
< 500 mm	H8
> 500 mm	+0,0004 mm x D

Overall eccentricity

The permissible overall eccentricity (static and dynamic eccentricity) between the shaft and the housing will depend on the seal profile and its circumferential velocity. Recommended values available on request.

Lead-in chamfers

d [mm]	α	C [mm]
200 ... 500	20° ... 30°	>7
500 ... 800		>9
800 ... 1.064		>11

Installation & assembly

The Merkel Radiamatic RPM 41 is supplied with a slight oversize at the outer diameter to provide a press fit.

An open housing with a cover plate and tightening screws is not required.

Available seal dimensions and profiles

S x L [mm]	D [mm]					
	200–260	261–300	301–360	361–470	471–684	685–1.064
15,0 x 16,0						
19,1 x 16,0						
19,1 x 18,0						
20,0 x 16,0						
20,0 x 18,0						
20,0 x 20,0						
22,0 x 20,0						
25,0 x 16,0						
25,0 x 18,0						
25,0 x 20,0						
25,0 x 22,0						
25,0 x 25,0						
30,0 x 30,0						
32,0 x 25,0						

Further dimensions on request.



INSTALLATION

Installation

Self-retaining, for new designs

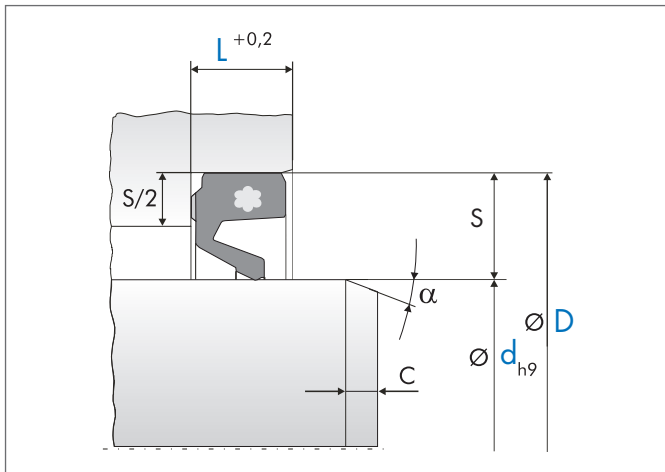

Cover plated, for new designs

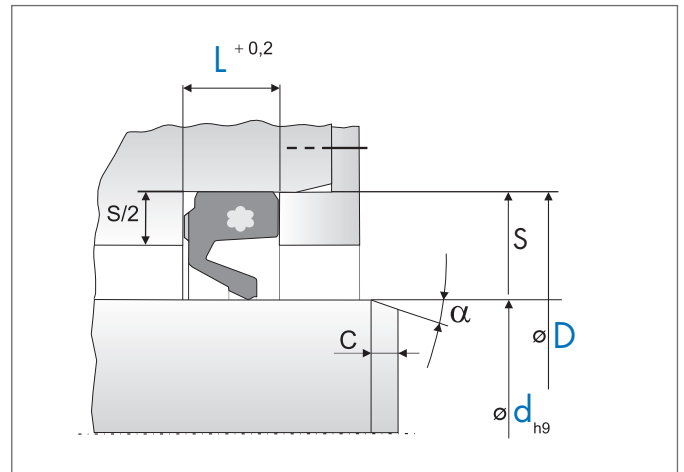

Order notes

For existing housings, only the following installation dimensions are required: **d x D x L**

Sealing systems for work rolls

Example 1

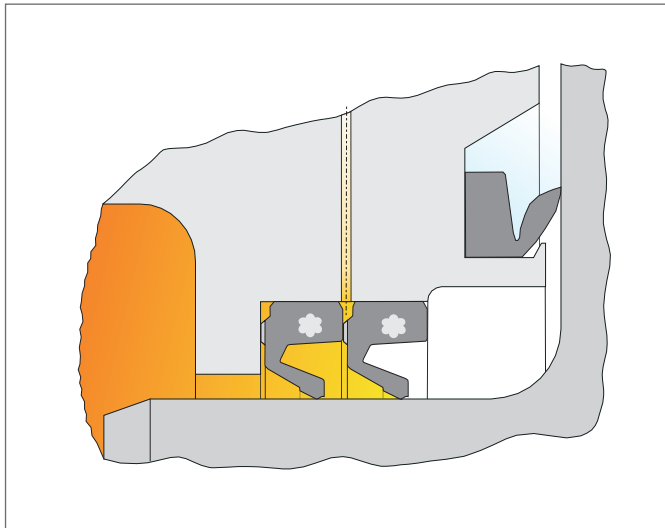

Sealing system featuring a Merkel Radiamatic RPM 41 rotary shaft seal and an Merkel Enviromatic EA deflector for grease-lubricated bearings and open housings.

www.fst.com

Example 2

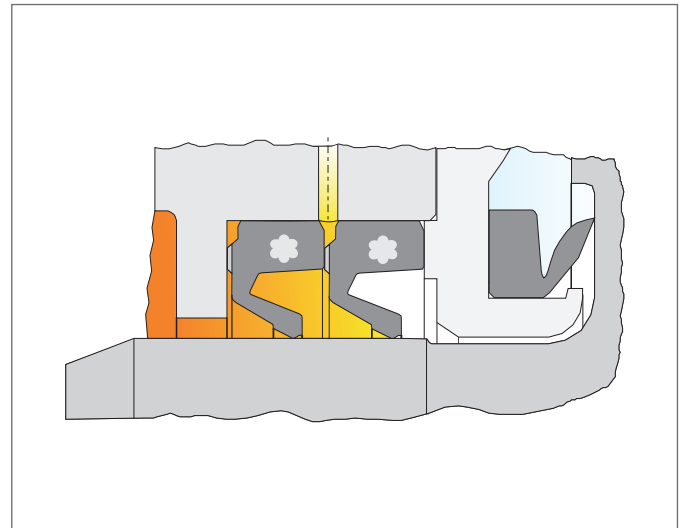

Sealing system featuring a Merkel Radiamatic RPM 41 rotary shaft seal and an Merkel Enviromatic EA deflector for grease-lubricated bearings and cover plated housings.